

## The Ultimate Visual Dictionary

This genre of reference books has been improving over the years. The concept remains steady. A compact illustration is crammed with labels that give the name for each part of the scene or object illustrated. In the first publishing wave the pictures were of more obscure objects—Renaissance costumes, say—but now they include subjects you might actually need to look up. Useful to writers, editors, and researchers who need to know the whatyamacallit's precise name. This one is best of breed so far.  
—KK

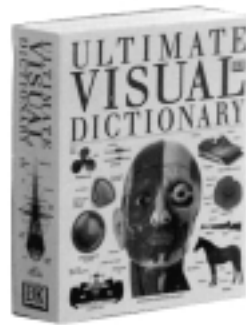

## The Ultimate Visual Dictionary

1998, 640 pages  
\$17  
DK Publishing

## Saddle

THE FIRST HORSEBACK RIDERS HAD NO SADDLES, they sat bareback, clinging to the animal's mane. Next came a simple cloth saddle. The leather saddle, which was invented about 2,000 years ago by the warriors of the Asian steppes, revolutionized horsemanship. In this saddle, horsemen could gallop toward the enemy, fire arrows in all directions, and stay on their horses. Modern saddles are of two main types. The Western saddle is a heavy, working saddle used mainly by ranch hands in the United States. It has a metal horn at the front for securing a lasso and a high cantle at the back to keep the rider on the horse. The English saddle is much lighter. Designed for sport, it allows the horse to gallop fast. Its drawback is that it provides less stability to stay on the horse; the rider must grip the animal with the knees.

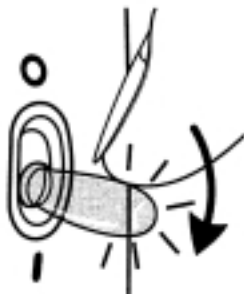
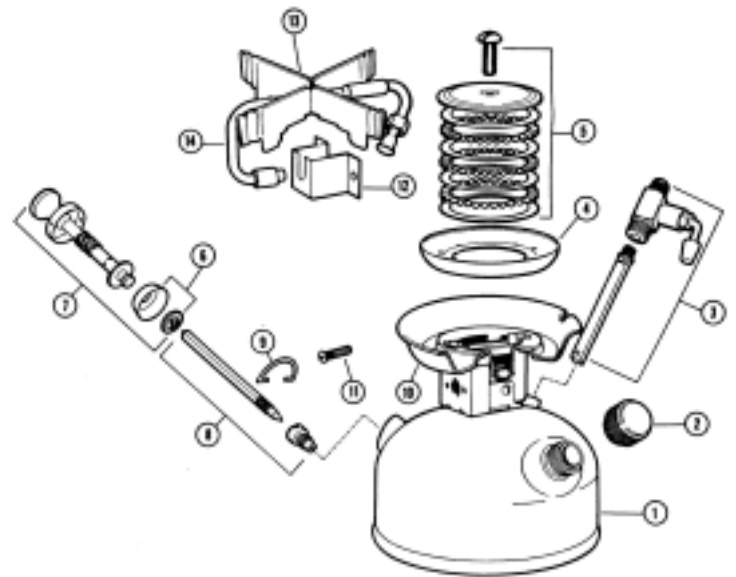
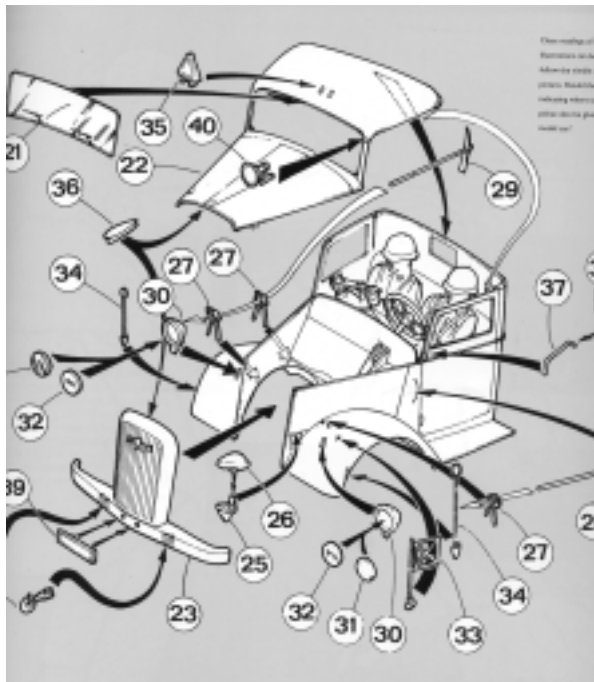
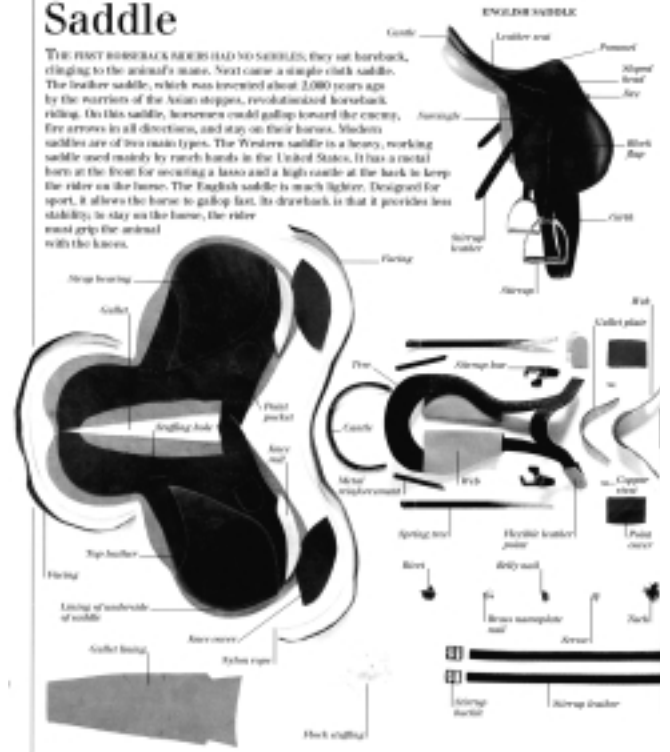

## Open Here

The Art of Instructional Design  
Paul Mijksenaar and Piet Westendorp  
1999, 144 pages  
\$29.95  
Joost Elffers Books  
Or powells.com

## Open Here

### The Art of Instructional Design

I thought I was the only one in the world stealing the safety instruction cards from airline seats because of their terrific folk graphics. For radically clear thinking

nothing can beat a really good set of wordless diagrams; hundreds of examples from around the world are paraded here. Designers of the world, please heed.

—KK